

MF301 Datasheet

MEDIUM-FLOW PRESSURE REGULATOR



Gas
 Liquid
 Diaphragm
 Piston
 Self-Venting
 Non-Venting
 Max Inlet: 300 bar (4,350 psi)
 Max Outlet: 300 bar (4,350 psi)
 Cv 2.0



INTRODUCING THE MF301...

The MF301 is a piston-sensed non-venting or self-venting regulator for gas or liquid applications. A PEEK™ seat is required for liquid applications.

The MF301 offers a **balanced main valve** as standard for maximum inlet and control pressures of up to 300 bar (4,350 psi). For higher pressures, please refer to our MF400/401.

Alternatively, an unbalanced option can be offered for applications with maximum inlet and control pressures of up to 50 bar (725 psi).

SPECIFICATION

Outlet Ranges	Up to 300 bar (4,350 psi)
Design Proof Pressure	150% max. working pressure
Seat Leakage	In accordance with ANSI/FCI 70-3
Weight	3.25kg (7.2lbs)

* Pressure regulator rating may be limited by connection type, Cv and/or seat material

STANDARD MATERIALS OF CONSTRUCTION

PART	MATERIALS
Body and Bonnet	AISI 316/316L Stainless Steel (UNS S31600/S31603)
Main Valve Pin	AISI 316/316L Stainless Steel (UNS S31600/S31603)
Soft Seat	PCTFE or PEEK™
Valve Spring	AISI 316 S42 Stainless Steel
Piston	AISI 316/316L Stainless Steel (UNS S31600/S31603)
Handwheel	Nylon
O-Rings	FKM/FPM
Loading Spring	Silicon Chrome Wire

FEATURES AND BENEFITS

1 PISTON SENSING ELEMENT

Perfect for use in challenging conditions.

2 BALANCED MAIN VALVE DESIGN

Improved control across the pressure range.

3 SELF-VENTING OR NON-VENTING

Versatile use for a range of applications.

4 LOWER ENTRY PLUG

For simplified seat servicing.

Product availability and specifications contained herein are subject to change without notice. Consult local distributor or factory for potential revisions and/or service related issues. Pressure Tech Ltd support with product selection recommendations only - it is the users responsibility to ensure the product is suitable for their specific application requirements.



DESIGNED AND BUILT IN THE UK

PRESSURE TECH LTD

Unit 24, Graphite Way, Hadfield, Glossop, Derbyshire, UK, SK13 1QH
 T +44 (0)1457 899 307
 E sales@pressure-tech.com
 W www.pressure-tech.com

271020

PAGE:
1 OF 4

MF301 Datasheet

MEDIUM-FLOW PRESSURE REGULATOR



Gas
 Liquid
 Diaphragm
 Piston
 Self-Venting
 Non-Venting
 Max Inlet: 300 bar (4,350 psi)
 Max Outlet: 300 bar (4,350 psi)
 Cv 2.0

DRAWINGS AND INSTALLATION DIMENSIONS

Dimensions shown for 1/2" NPT option - please contact the office for additional connections options.

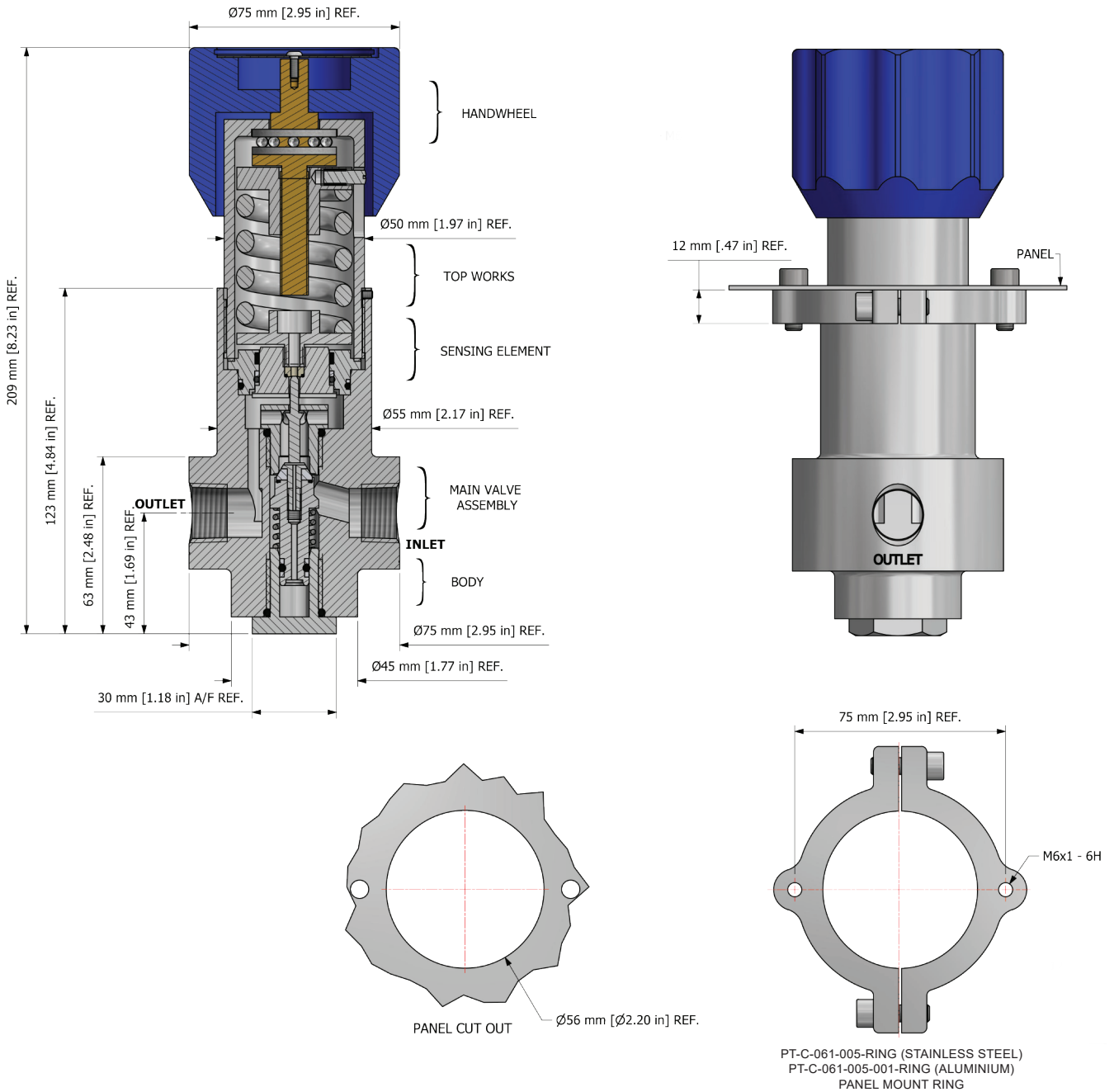

Note:

All gauge ports are 1/4" NPT as standard.

Product availability and specifications contained herein are subject to change without notice. Consult local distributor or factory for potential revisions and/or service related issues. Pressure Tech Ltd support with product selection recommendations only - it is the users responsibility to ensure the product is suitable for their specific application requirements.



DESIGNED AND BUILT IN THE UK

PRESSURE TECH LTD
 Unit 24, Graphite Way, Hadfield, Glossop, Derbyshire, UK, SK13 1QH
 T +44 (0)1457 899 307
 E sales@pressure-tech.com
 W www.pressure-tech.com

MF301 Datasheet

MEDIUM-FLOW PRESSURE REGULATOR



Gas
 Liquid
 Diaphragm
 Piston
 Self-Venting
 Non-Venting
 Max Inlet: 300 bar (4,350 psi)
 Max Outlet: 300 bar (4,350 psi)
 Cv 2.0

FLOW CURVE

Flow Rate, Q (sfcM) - Nitrogen, N₂

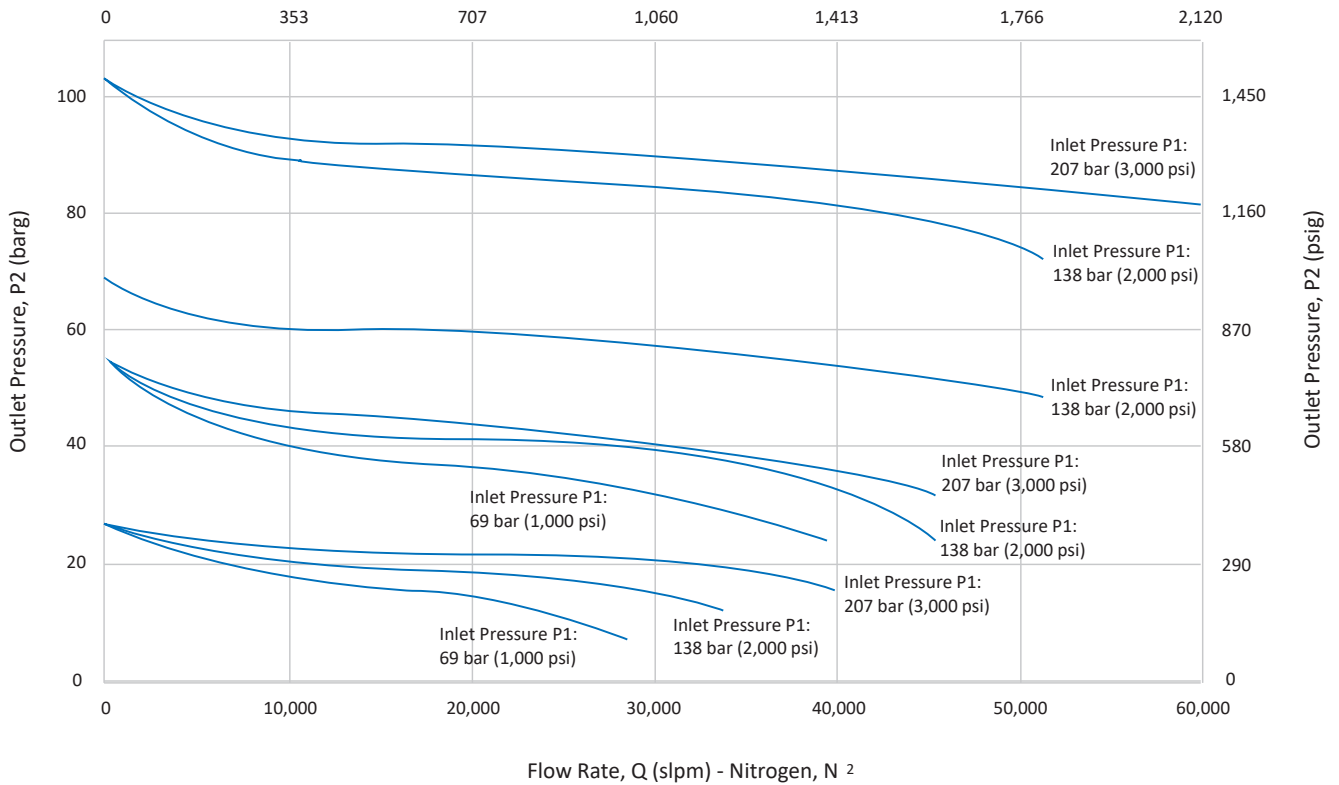

PORTING CONFIGURATIONS

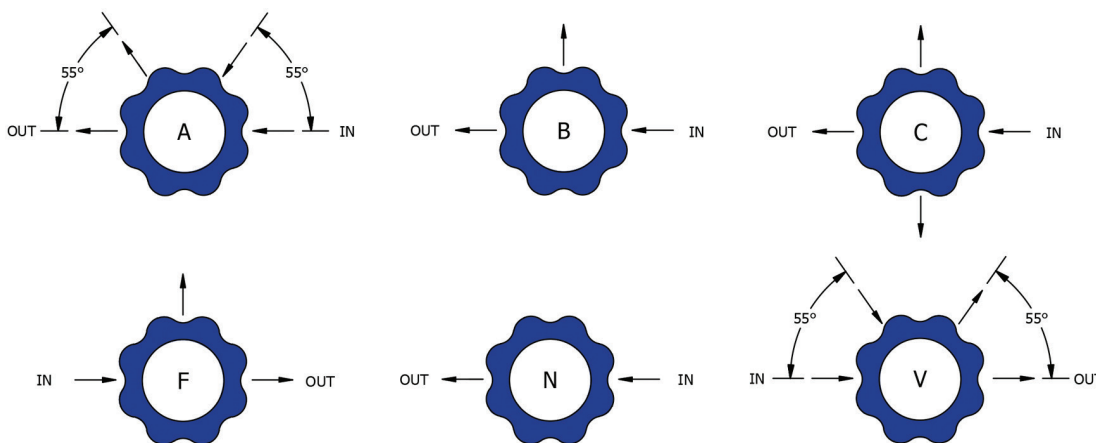

Note:
Additional porting configurations are available - please contact the office for further information.

Product availability and specifications contained herein are subject to change without notice. Consult local distributor or factory for potential revisions and/or service related issues. Pressure Tech Ltd support with product selection recommendations only - it is the users responsibility to ensure the product is suitable for their specific application requirements.



DESIGNED AND BUILT IN THE UK

PRESSURE TECH LTD
 Unit 24, Graphite Way, Hadfield, Glossop, Derbyshire, UK, SK13 1QH
 T +44 (0)1457 899 307
 E sales@pressure-tech.com
 W www.pressure-tech.com

271020

PAGE: 3 OF 4

MF301 Datasheet

MEDIUM-FLOW PRESSURE REGULATOR



Gas
 Liquid
 Diaphragm
 Piston
 Self-Venting
 Non-Venting
 Max Inlet: 300 bar (4,350 psi)
 Max Outlet: 300 bar (4,350 psi)
 Cv 2.0

ORDERING INFORMATION

To build a Pressure Tech part number, simply combine the characters identified below in sequence:

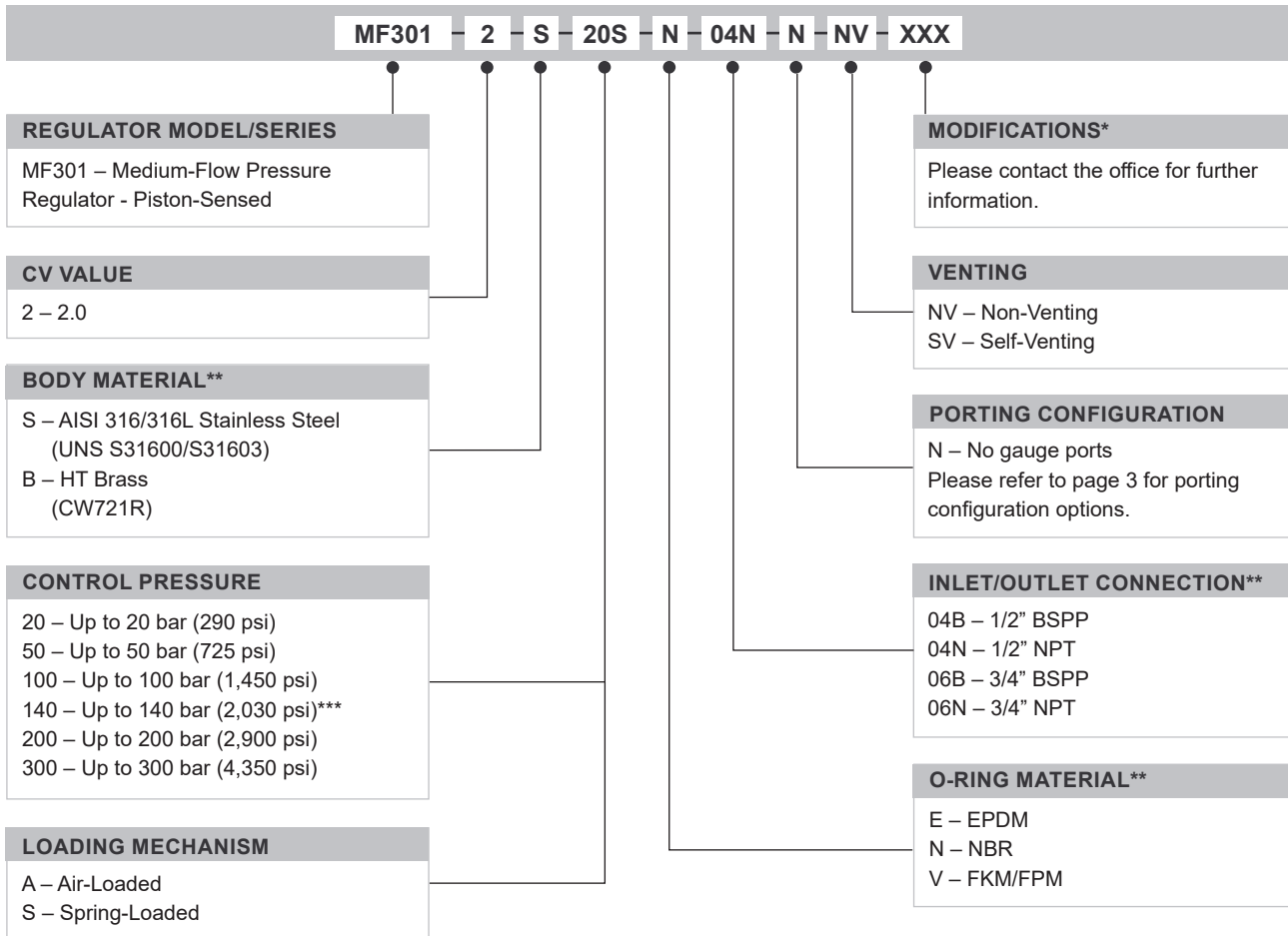

OPTIONAL EXTRAS		
	PART NUMBER	DESCRIPTION
Service Kit	SRK-MF301-2-B...	Various 'Balanced' options available
Service Kit	SRK-MF301-2-U...	Various 'Unbalanced' options available
Panel Mount Ring	PT-C-061-005-RING	Stainless Steel panel mount ring
Panel Mount Ring	PT-C-061-005-001-RING	Aluminium panel mount ring

Note:
Ancillary equipment also available

TRADEMARKS: Inconel® is a registered trademark of Inco Alloys International
PEEK™ is a trademark of Victrex PLC

* Where applicable
** Other connections/materials may be available - please contact the office
*** Air-loaded only

Product availability and specifications contained herein are subject to change without notice. Consult local distributor or factory for potential revisions and/or service related issues.
Pressure Tech Ltd support with product selection recommendations only - it is the users responsibility to ensure the product is suitable for their specific application requirements.



DESIGNED AND BUILT IN THE UK

PRESSURE TECH LTD
 Unit 24, Graphite Way, Hadfield, Glossop, Derbyshire, UK, SK13 1QH
 T +44 (0)1457 899 307
 E sales@pressure-tech.com
 W www.pressure-tech.com

271020